

## Installation

- Perpendicularity and parallelism between parts, support and pressing forces are crucial to achieving acceptable run-out of hub, impeller and seal. Radial and axial run-out reduces bearing life and can lead to shaft breakage.
- Press parts together with steady even pressure to avoid distortion.

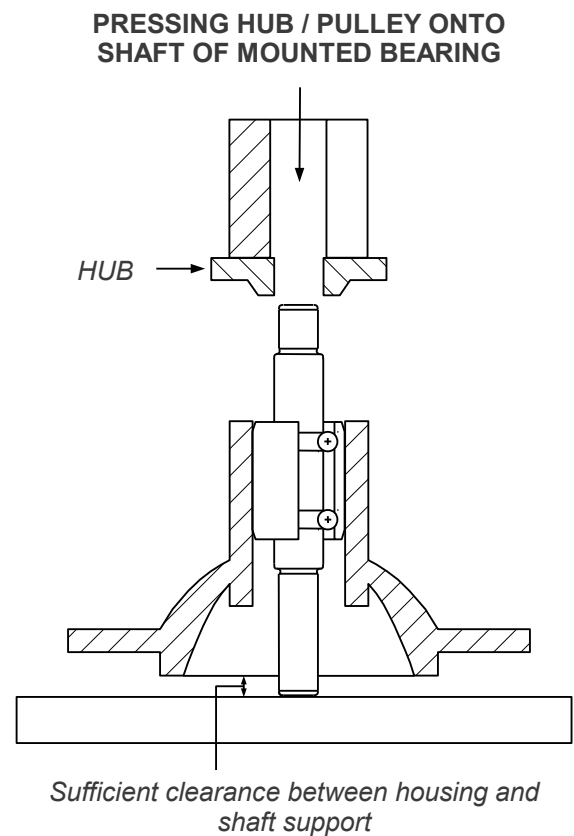
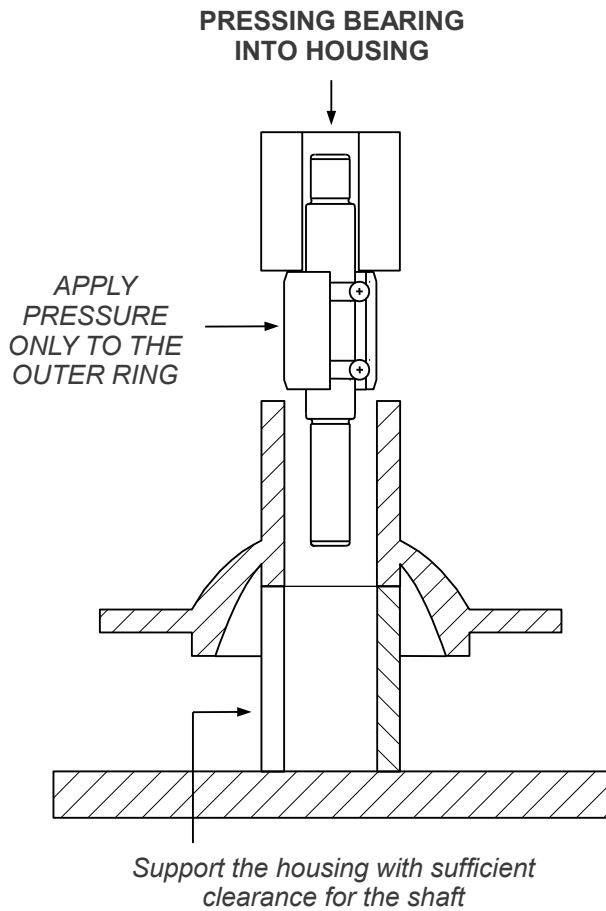

***Applying force between shaft and outer race will damage bearing.***